

P. C. B Layout
(Copper-sided view)

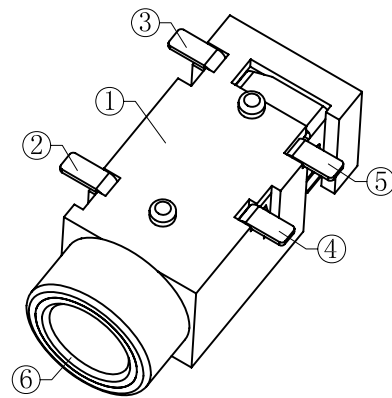

Ordering information:
 TPJ-3A910 - □ 9T 0A S 00 1
 (1) (2) (3) (4) (5) (6) (7)

- (1): Series No.
- (2): Schematic option: B, D
- (3): Material of housing:
9T=PA9T
- (4): Housing color:
Zero-0A=Black
- (5): Terminal plating:
S=Silver (Ag)
- (6): Special option:
00=No special option
- (7): Packing mode:
1=Tape reel packing

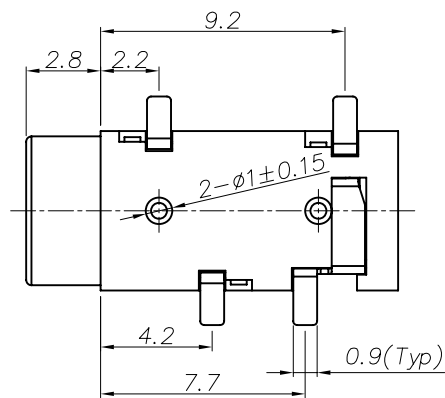
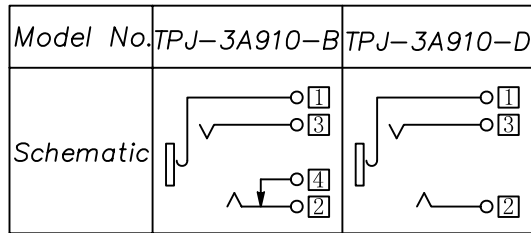

SPECIFICATION
 1. Rating : DC 30V 0.5A;
 2. Contact resistance: ≤30mΩ;
 3. Insulation resistance: ≥100MΩ (DC250V);
 4. Withstand voltage: 500VAC ;
 5. Insertion and extraction force: 3-30N;
 6. life test: 5000 cycles.

⑥	Bushing	1	Copper alloy	TPJ-3A910F-88	Nickel Plating
⑤	Shunt terminal	④	Brass 0.2t	TPJ-3A910-04	Silver Plating
④	Ring spring	③	Titanium copper 0.2t	TPJ-3A910-01	Silver Plating
③	Tip spring	②	Titanium copper 0.2t	TPJ-3A910-02	Silver Plating
②	Earth spring	①	Titanium copper 0.2t	TPJ-3A910-01	Silver Plating
①	Housing		PA9T, UL94 V-0	TPJ-3A910-S1	
NO.	DESCRIPTION	QTY	MATERIAL	PART NO.	PLATING

TENGXING ELECTRONICS CO., LTD

TOLERANCES UNLESS OTHERWISE SPECIFIED LINEAR: ±0.030 ANGULAR: ±3°		SIGNATURES		DATE	TITLE
REVISIONS		DRAWN	Eric	2009.05.28	EARPHONE JACK
A		CHK'D	Alex	2009.05.28	
	SCALE	APPV'D	Rex	2009.05.28	
					NO. TPJ-3A910

△			
△			
△			
△			
△			
SYM	DISCRIPTION	DATE	APPROVED