

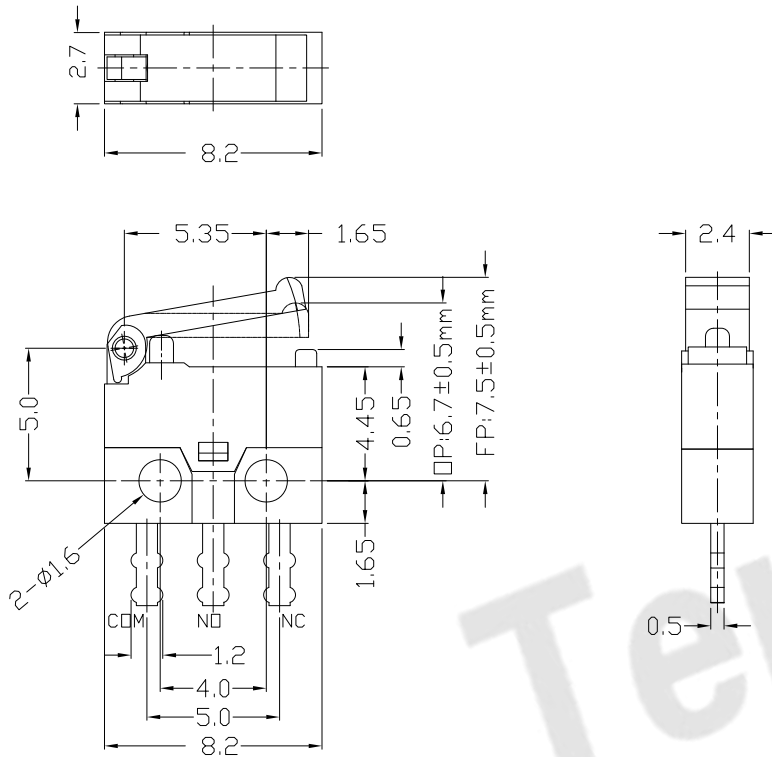

RoHS
Compliant
2002/95/EC

REV.	ECN. NO.	APPD.

DIMENSIONS



MODEL CODE

DS037-01X-XX-C

1 2 3 4 5

- 1.Series : DS037
- 2.Actuator Button : 00=Non-lever 01-99=Lever
- 3.Termination : see chart(P/C/D/C1/D1)
- 4.Operating Force : see chart
- 5.Cover type : C

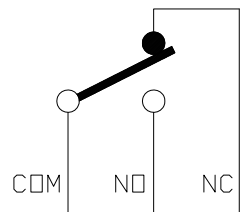

CIRCUIT DIAGRAM

1.Functional spec

1.1 Rated Voltage	DC 6V
1.2 Rated Current	0.3A
1.3 Contact Resistance	≤50mΩ(Initial value)
1.4 Operating Force	10~45gf
1.5 Bounce Time	
1.6 Free Position	7.5±0.5mm
1.7 Operating Position	6.7±0.5mm
1.8 Position Travel	
1.9 Return Force	

2.Reliable Rating

2.1 Mechanical Life	100,000 CYCLES
2.2 Electrical Life	50,000 CYCLES
2.3 Insulation Resistance	≥100MΩ DC250V
2.4 Withstand Voltage	AC250V 1 minute
2.5 Soldering Technic	Hand/Wave soldering
2.6 Operating Temper	-25°C ~ +85°C
2.7 Ambient Humidity Used	<85%RH

Tolerance: ±0.2		UNITS	东莞市腾兴电子有限公司			
		mm				
		MAT'L	SEE NOTE		TITLE: Miniature MICRO SWITCH DS037 SERIES	
		FINISH	SEE NOTE		PART NO.: DS037-01P-30-C	
		Q'TY	DR: Ricky 2017/7/19		DWG NO.: ATD-01X-30-C	
<small>THESE DRAWINGS AND SPECIFICATIONS ARE THE PROPERTY OF ACCURATE INNOTECH INC AND SHALL NOT BE REPRODUCED, COPIED OR USED IN ANY MANNER WITHOUT THE PRIOR WRITTEN CONSENT OF ACCURATE INNOTECH INC.</small>			CHKD: Ricky 2017/7/19		SCALE	
			APPD:		1:1	SHEET 1/2



RoHS
Compliant
2002/95/EC

REV.	ECN.	NO.	APPD.

Terminal Type

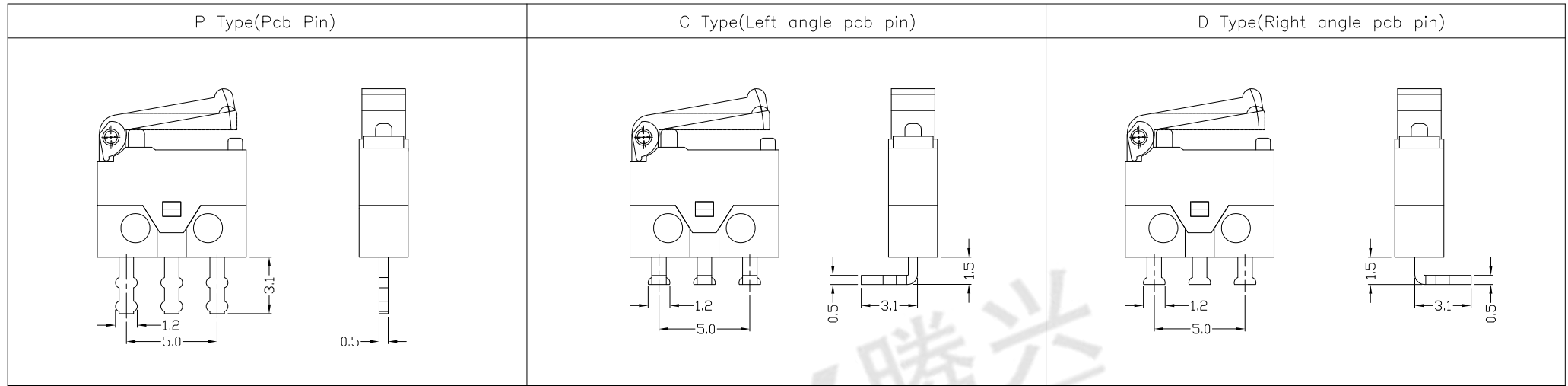

Structure chart

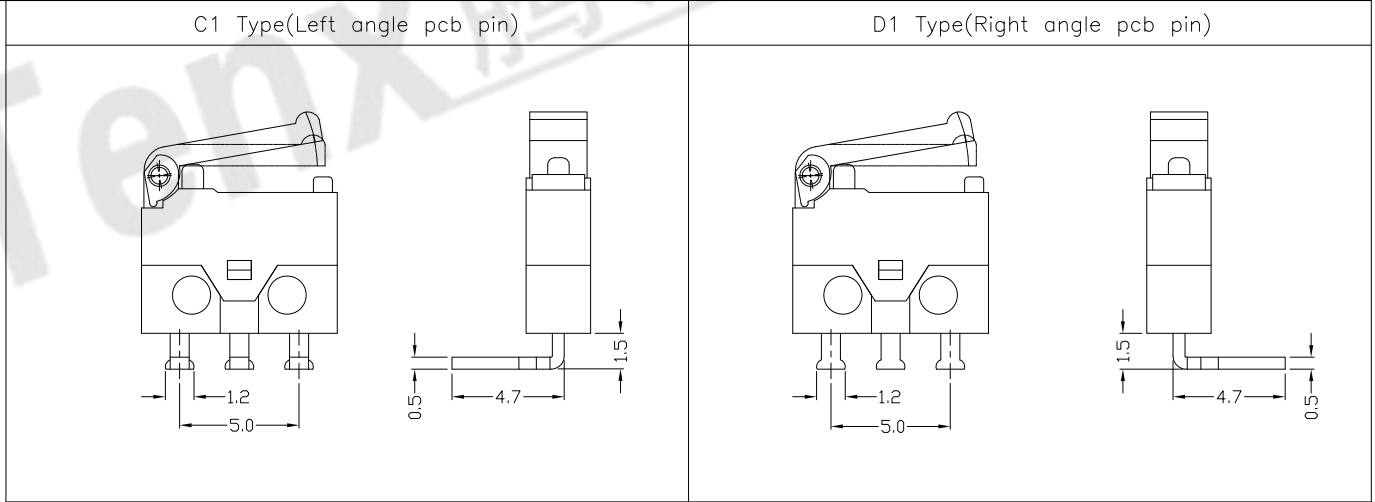
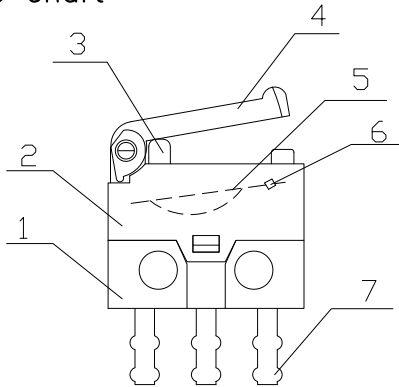

Material list

8				
7	Terminal	C2680	3	
6	Contact	Silver alloy	1	
5	Spring Plate	C1720	1	
4	Lever	Nylon	1	
3	Button	Nylon	1	
2	Case	Nylon	1	
1	Base	Nylon	1	
NO.	PARTS	MATERIAL	Q'TY	FINISHING

Tolerance:±0.2

UNITS mm

MAT'L

SEE NOTE

FINISH

SEE NOTE

Q'TY



东莞市腾兴电子有限公司

TITLE: Miniature MICRO SWITCH DS037 SERIES

PART NO.: DS037-01X-30-C

DR: Ricky 2017/7/19

DWG NO.: ATD-01X-30-C

CHKD: Ricky 2017/7/19

SCALE SHEET REV. CUSTOMER DRAWING

APPD:

1:1 2/2 A

THESE DRAWINGS AND SPECIFICATIONS ARE THE PROPERTY OF ACCURATE INNOTECH INC AND SHALL NOT BE REPRODUCED, COPIED OR USED IN ANY MANNER WITHOUT THE PRIOR WRITTEN CONSENT OF ACCURATE INNOTECH INC.