

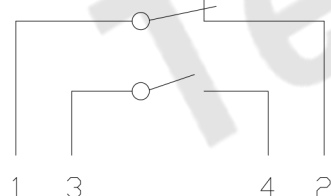

RoHS Compliant
2002/95/EC

REV.	ECN. NO.	APPD.

DIMENSIONS

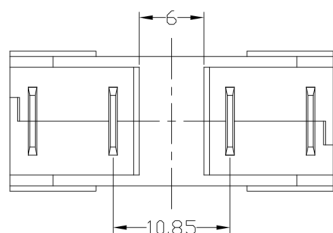
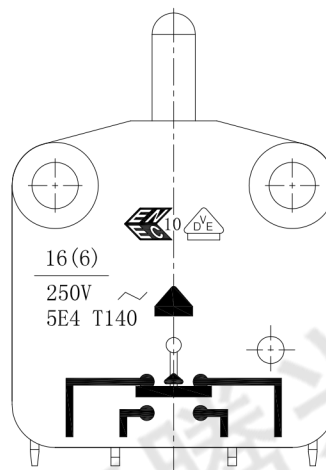
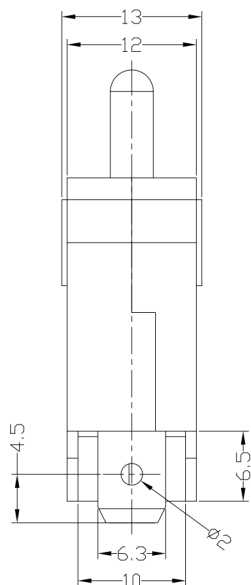
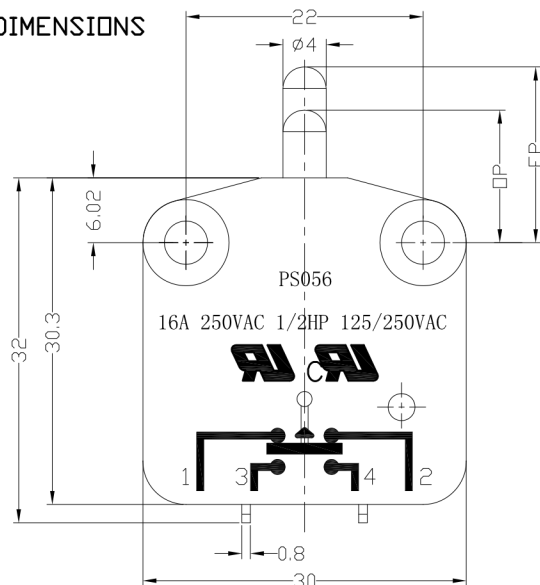

CIRCUIT DIAGRAM

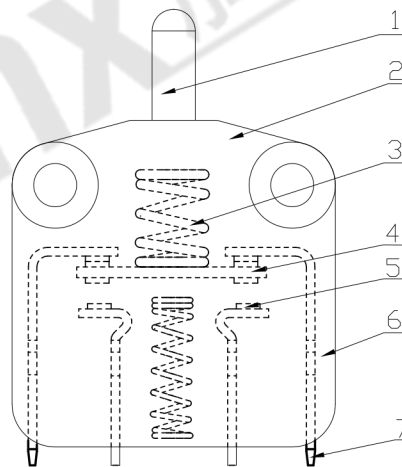

Structure chart

MODEL CODE

PS056-01N-XX

1 2 3 4

- 1.Series : PS056
- 2.Actuator : 01-99=Lever
- 3.Termination : N
(3=PUSH ON / 2=PUSH OFF)
- 4.Operating Force : see chart

1.Functional spec

1.1 Rated Voltage(AC)	AC 250V
1.2 Rated Current(AC)	16A
1.3 Contact Resistance	≤50mΩ(Initial value)
1.4 Operating Force	100±50gf 200±50gf
1.5 Bounce Time	
1.6 Free Position	14.9±0.5mm
1.7 Operating Position	13.0±0.5mm
1.8 Position Travel	
1.9 Return Force	

2.Reliable Rating

2.1 Mechanical Life	100,000 CYCLES
2.2 Electrical Life	50,000 CYCLES
2.3 Insulation Resistance	≥100MΩ DC250V
2.4 Withstand Voltage	AC1500V 1 minute
2.5 Soldering Technic	Hand Soldering
2.6 Operating Temper	-25°C ~ +140°C
2.7 Ambient Humidity Used	<85%RH

Material list

NO.	PARTS	MATERIAL	Q'TY	FINISHING
9				
8				
7	Terminal	C2680	4	
6	Lower Housing	PBT	1	
5	Contact	Silver alloy	6	
4	Change Plate	C2680	1	
3	Spring	SUS304	2	
2	Upper Housing	PBT	1	
1	Button	PBT	1	

Tolerance: ±0.2

UNITS mm

MAT'L

SEE NOTE

FINISH

SEE NOTE

Q'TY



东莞市腾兴电子有限公司

TITLE: MICRO SWITCH PS056 SERIES

PART NO.: PS056-01N-XX

DR: Ricky 2017/6/8

DWG NO.: ATD-01N-XX

CHKD: Ricky 2017/6/8

APPD:

SCALE	SHEET	REV.	CUSTOMER DRAWING
1:1	1/1	A	

THESE DRAWINGS AND SPECIFICATIONS ARE THE PROPERTY OF ACCURATE INNOVATECH INC AND SHALL NOT BE REPRODUCED, COPIED OR USED IN ANY MANNER WITHOUT THE PRIOR WRITTEN CONSENT OF ACCURATE INNOVATECH INC.