

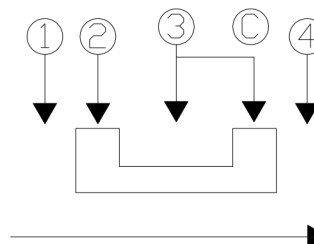

RoHS
Compliant
2002/95/EC

REV.	ECN. NO.	APPD.

DIMENSIONS

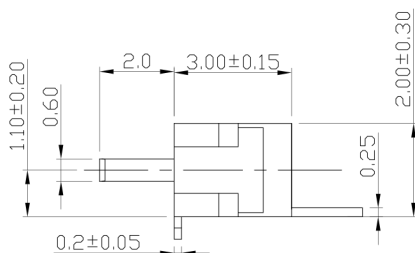
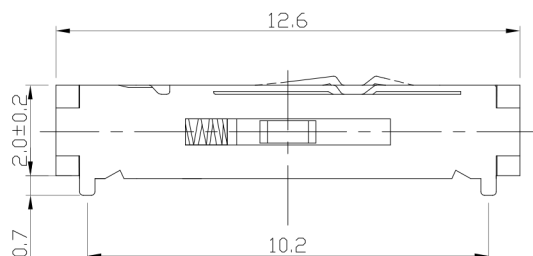

CIRCUIT DIAGRAM

MODEL CODE

AS-1370RL-**B**

Knob Color	
B	Black

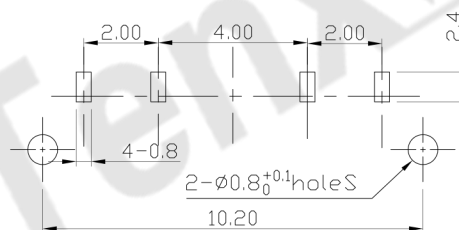
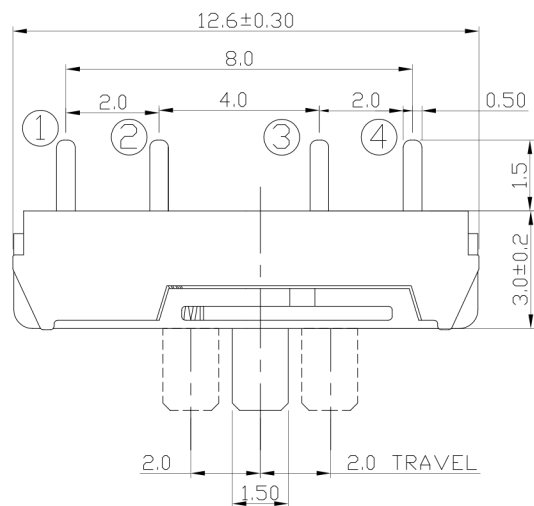

P.C.B LAYOUT
TOP VIEW

ELECTRO-MECHANICAL CHARACTERISTICS

Refer to additional specifications

Rating	DC 6V 0.3A
Circuit	1P3T
Contact Resistance	70mΩ Max.
Travel	2.0mm
Operating Force	150±50gf
Operating Life(cycles)	10,000

8					WITHIN 1.5mm:±0.1mm	UNITS mm	东莞市腾兴电子有限公司					
7					OVER 1.5mm:±0.2mm	MAT'L						
6						SEE NOTE	TITLE:	PART NO.:				
5							MINI SLIDE SWITCH / HORIZONTAL	AS-1370RL SERIES				
4	CONTACT FOOT	BRASS	4	Ag-Plating		FINISH	DR:	Ricky 2015/04/10	DWG NO.:			
3	COAT	STEEL	1			SEE NOTE	CHKD:	Ricky 2015/04/10	ADL-1370RL			
2	BUTTON	PA9T	1			Q'TY	APPD:		SCALE	SHEET	REV.	CUSTOMER
1	HOUSING	PA9T	1						4:1	1/1	A	DRAWING
NO.	PARTS	MATERIAL	Q'TY	FINISHING								

THESE DRAWINGS AND SPECIFICATIONS ARE THE PROPERTY OF ACCURATE INNOVATECH INC AND SHALL NOT BE REPRODUCED, COPIED OR USED IN ANY MANNER WITHOUT THE PRIOR WRITTEN CONSENT OF ACCURATE INNOVATECH INC.