

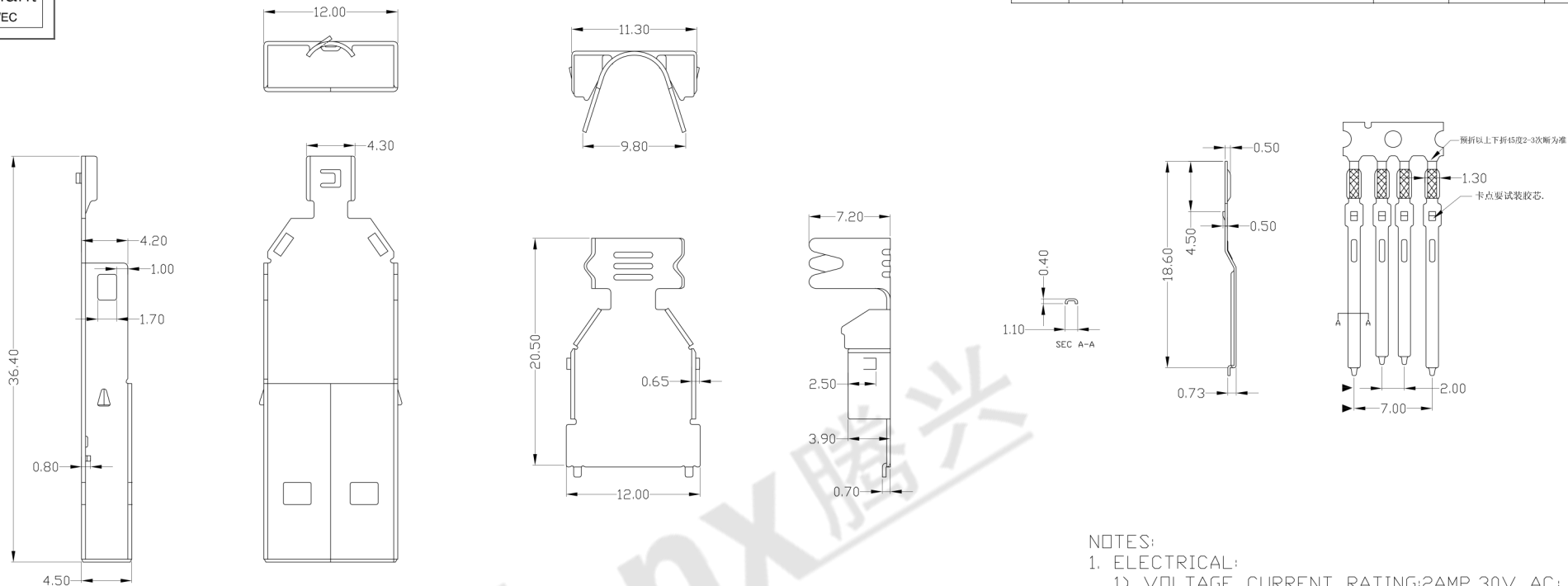

RoHS  
Compliant  
2002/95/EC

REV	LTR	DESCRIPTION	DATE	REVISER	APPD



- NOTES:
- ELECTRICAL:
    - VOLTAGE CURRENT RATING: 2AMP, 30V AC;
    - INSULATION RESISTANCE: 1000MΩ MIN;
    - CONTACT RESISTANCE: 30mΩ MAX;
    - WITHSTANDING VOLTAGE: 500V AC;
    - OPERATING TEMPERATURE: -55°C TO +85°C.
  - Mechanical:
    - Mating Force: 35N MAX
    - Unmating Force: 10N MIN.
  - NOTE: 1. DIMENSIONS MARKED "▼" TO BE CHECKED BY Q.C & IPQC.
  - PART NO.

USAM-04\*N-1\*S802

W: WHITE  
 B: BLACK  
 1: PBT  
 2: PA6T  
 3: PA9T  
 4: LCP

1: Au 1U'  
 6: Au 30U'

Bill of materials:

NO	PARTS	MATERIAL	QTY	FINISHING
4	HOUSING	PBT	1	UL 94V-0
3	UP SHELL	SPCC	1	PLATED NICKEL
2	DOWN SHELL	SPCC	1	PLATED NICKEL
1	TERMINAL	COPPER ALLOY	4	PLATED GOLD/TIN

X.	X.* ±2'	UNITS
X ±0.35	X.* ±2'	mm
.X ±0.3	.X* ±1'	MAT'L
.XX ±0.25	.XX*	SEE NOTE
.XXX ±0.15	.XXX*	FINISH
		SEE NOTE
		Q'TY

**东莞市腾兴电子有限公司**

TITLE: USB A/M 长体直线型平端数据线夹 (四件套)	PART NO.: USAM-04*N-1*S802
DR: gan 2012/7/04	DWG NO.: AII-S802
CHKD: gan 2012/7/04	SCALE SHEET REV. CUSTOMER 1:1 1/1 B DRAWING
APPD:	

THESE DRAWINGS AND SPECIFICATIONS ARE THE PROPERTY OF ACCURATE INNOTECH INC AND SHALL NOT BE REPRODUCED, COPIED OR USED IN ANY MANNER WITHOUT THE PRIOR WRITTEN CONSENT OF ACCURATE INNOTECH INC.

